

P74JA Type Differential Pressure Control With Floating Action Switch

Application

The P74JA differential pressure control is commonly used on water systems to control a pressure differential between supply and return lines. The control's SPDT floating action contacts position a motor actuated valve operated by a Johnson Controls M81 or Series M100A motor actuator. In atypical application the valve is located in a bypass line around the system pump. When the system pressure differential increases above the control's set point, the valve opens further. More water is diverted through the bypass valve, resulting in a reduction in system pressure differential. A reduction in the pressure differential causes the valve to begin closing and results in an increase in system pressure differential.

The P74JA is suitable for use on other air or liquid pressure differential applications where SPDT non-snap acting switching is desired.

All Series P74 differential pressure controls are designed for use *only* as operating controls. Where an operating control failure would result in personal injury and/or loss of property, it is the responsibility of the installer to add devices (safety, limit controls) or systems (alarm, supervisory systems) that protect against, or warn of, control failure.

Features

- Single-pole, double-throw, totally enclosed non-snap acting Pennswitch.
- 1/4 in. flared tube pressure connection on the sensing element permits easy field

installation.



Fig. 1 -- Exterior view of a P74JA Differential Pressure Control.

- Direct reading scale for quick set point determination.
- Pressure differential setting can be easily changed without removing the cover.

General Description

The P74JA differential pressure control incorporates two highly sensitive pressure elements which directly oppose each other. A change in pressure at either element causes appropriate positioning of the switch mechanism which is then used to control supplementary equipment such as motor actuated valves. The switch mechanism provides SPDT non-snap acting (floating) action; as such, the movable contact (common) is made to either of the two fixed contacts or positioned between the two (no contact made).

Specifications

Product	P74JA	Differential Pressure Control
Scale Range		8 to 60 PSI (55 to 414 kPa)
Operating Pressure Differential		2 PSI (14 kPa), Fixed
Maximum Low Pressure Bellows Overrun*		180 PSIG (1241 kPa)
Maximum Allowable Difference In Pressure Between Bellows		120 PSI (830 kPa)
Electrical Rating		1 Ampere, 24 VAC., 50/60 Hz
Contact Unit		SPDT, Totally Enclosed Non-Snap Acting (Floating) Pennswitch
Material	Case	.062" (1.6 mm) Cold Rolled Steel
	Cover	.025" (0.6 mm) Cold Rolled Steel
Finish		Gray Baked
Mounting		Mounts to Flat Surface or With a 271-51 Universal Mounting Bracket
Wiring Connections		Color Coded Screw Type Terminal
Shipping Weight	Individual Pack	2.4 lb (1.1 kg)
	Overpack of 25 Units	62.5 lb (28.4 kg)
Ambient Operating Temperature	Minimum	30°F (-1°C)
	Maximum	140°F (60°C)

*Bellows overrun pressure is the pressure supplied to the low pressure side of the control.

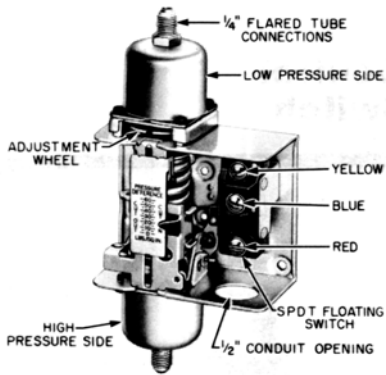

Fig. 2 -- Interior view of a P74JA Differential Pressure Control.

CAUTION: This control should not be used to control relays or starters as short cycling or chattering will occur.

Ordering Information

To order, specify P74JA.

Installation

Mounting

Mount the control in any position to a flat surface or panel board. Use two screws or bolts through the holes in the back of the case, or use Part Number 271-51 universal mounting bracket. The control should be mounted so the connections on the bellows are above the liquid level of the equipment on which it is used. This reduces the possibility of accumulating foreign matter inside the bellows.

General Instructions

1. Make sure the control is not installed on equipment which would require the control to handle a load in excess of its electrical rating. For maximum electrical rating and contact action of the control, see the label on the inside of the control cover.
2. Purge all tubing and lines before connecting the pressure control.

3. Avoid sharp bends or kinks in capillary tubing.
4. Coil and secure excess capillary length to avoid vibration. Allow some slack in capillary to avoid "violin string" vibration which can cause tubing to break. Do not allow tubing to rub against surrounding surfaces or objects where friction can damage capillary.

Wiring

CAUTION: Disconnect the electrical power supply before wiring connections are made to prevent possible electrical shock or damage to the equipment.

Make all wiring connections using copper conductors only, and in accordance with local ordinances and the National Electrical Code. Use Number 18 or larger wire for all connections to the motor actuator. Number 14 wire should be used on runs over 500 feet long.

All splices are to be made in junction boxes utilizing approved solderless connectors or by soldering and then taping the connections.

Note: Use terminal screws furnished (8-32 x 1/4 in. binder head). Substitution of other screws may cause problems in making proper connections.

Adjustment

To change the set point, turn the adjustment wheel to the left or right as viewed from the front of the control. (See Fig. 2.)

Insert a screwdriver into the slot in the wheel and rotate the wheel until the scale pointer is opposite the set point desired. Rotate the wheel to the left to increase the differential set point or to the right to decrease the differential set point.

Checkout Procedure

Before leaving the installation, observe at least three complete operating cycles to be sure that all components are functioning correctly.

Repairs and Replacement

Field repairs must not be made except for replacement of the cover. For a replacement control or cover contact the nearest Johnson Controls distributor.

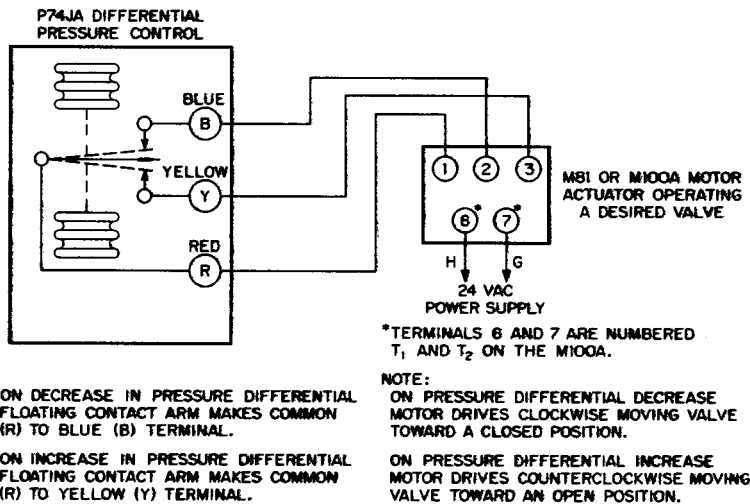
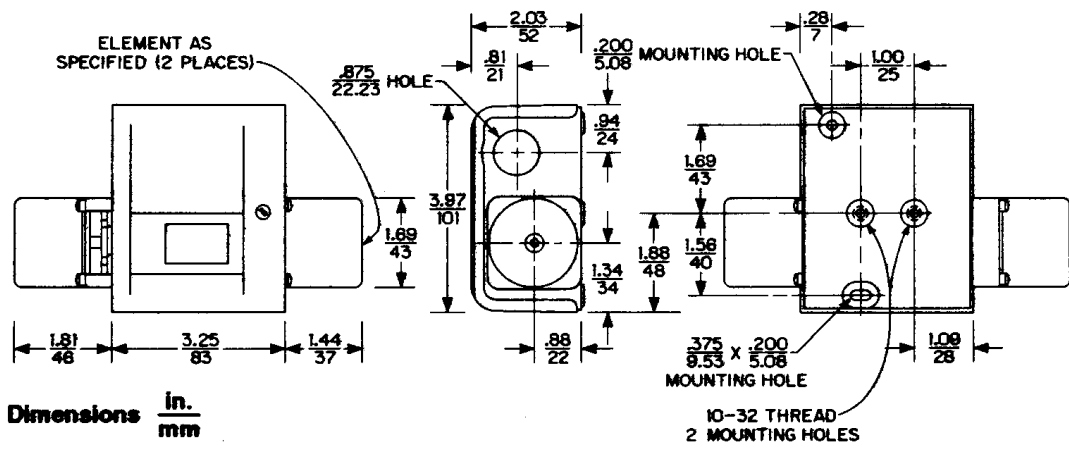

Fig. 3 -- Typical wiring hookup showing connections to a motor actuator.



Performance specifications appearing herein are nominal and are subject to accepted manufacturing tolerances and application variables.

Notes



Controls Group
507 E. Michigan Street
P.O. Box 423
Milwaukee, WI 53202

Printed in U.S.A.